

REVISIONS				
ZONE	REV	DESCRIPTION	DATE	APPROVED

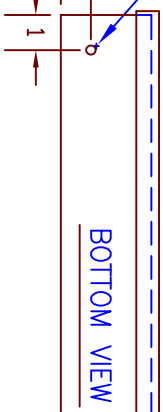
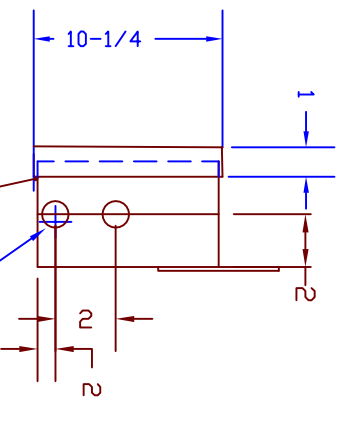
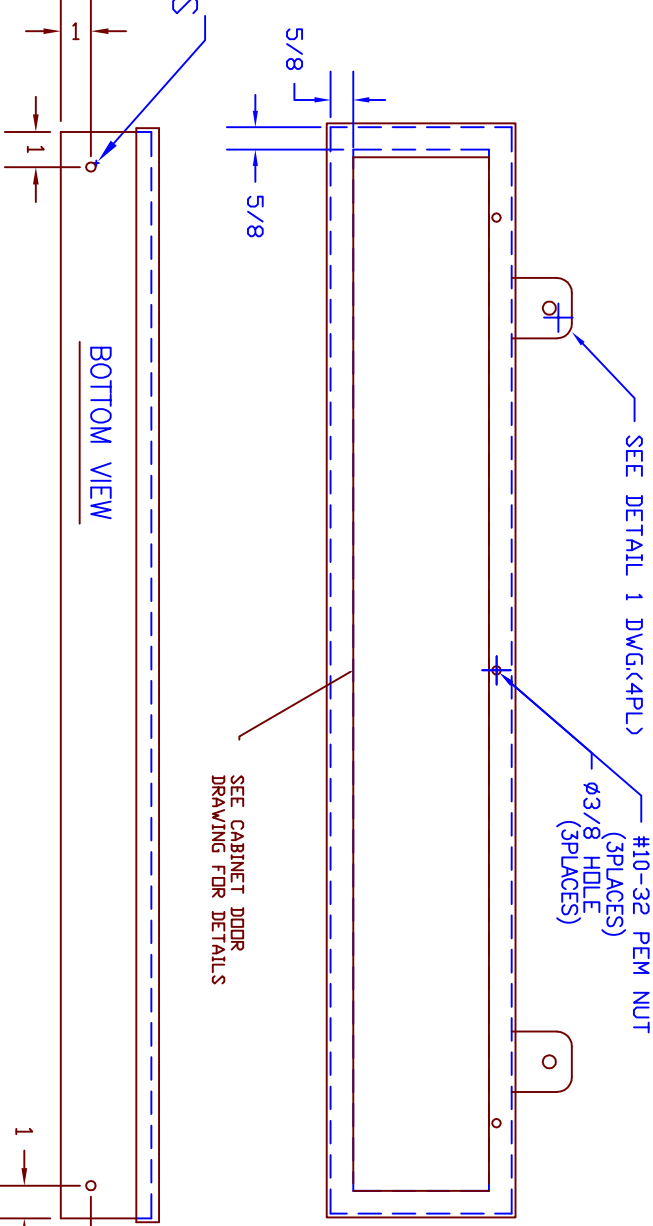
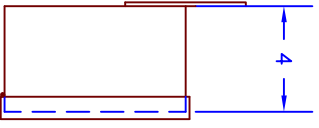
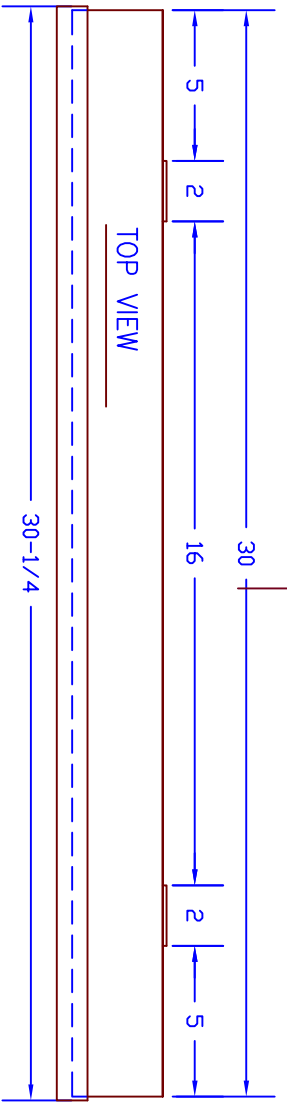

- NOTES:
- 1-HOLES ON COVER MUST MATCH THE HOLES ON THE CABINET.
 - 2-ALL DIMENSIONS ARE IN INCHES.
 - 3-ALL WELDS TO BE SANDED READY FOR PAINT.

4- MATERIAL USED - aluminum .062

EDI Inc. 135 S CHURCH ADDISON IL60101 ph#630 628-0658		DESCRIPTION: (30x10x4) CABINET FOR EDV111-1680	
APPROVED BY:	SIZE: B	FSCM NO.:	DWG NO.: R:\CABINET-MA\1400-028-ALUM-EDV111-1680-IND
DRAWN BY: MERI B. ph#630.628.0658 x303	SCALE: NONE	P/N: 1400-028	SHEET: 1 OF 2